

NEW M BRACKET

THE RIGHT SOLUTION FOR LOADS FROM 300 TO 500 KG



Tellure Rôta presents the new medium-duty bracket, with a load capacity of 500 daN.

Why have we introduced it?

In order to optimise load capacities of all wheels with capacities between 300 and 500 daN.

With the M bracket, Tellure Rôta today offers a complete and optimised range of products regarding the price-performance ratio for load capacities between 100 and 3.500 kg.

How is it made?

It is manufactured based on the design of the existing NL standard-duty castor but with a thicker steel plate.

It can be coupled to wheels with diameter of 150-160-200 mm.

How to choose the right product on the base of the load capacity?

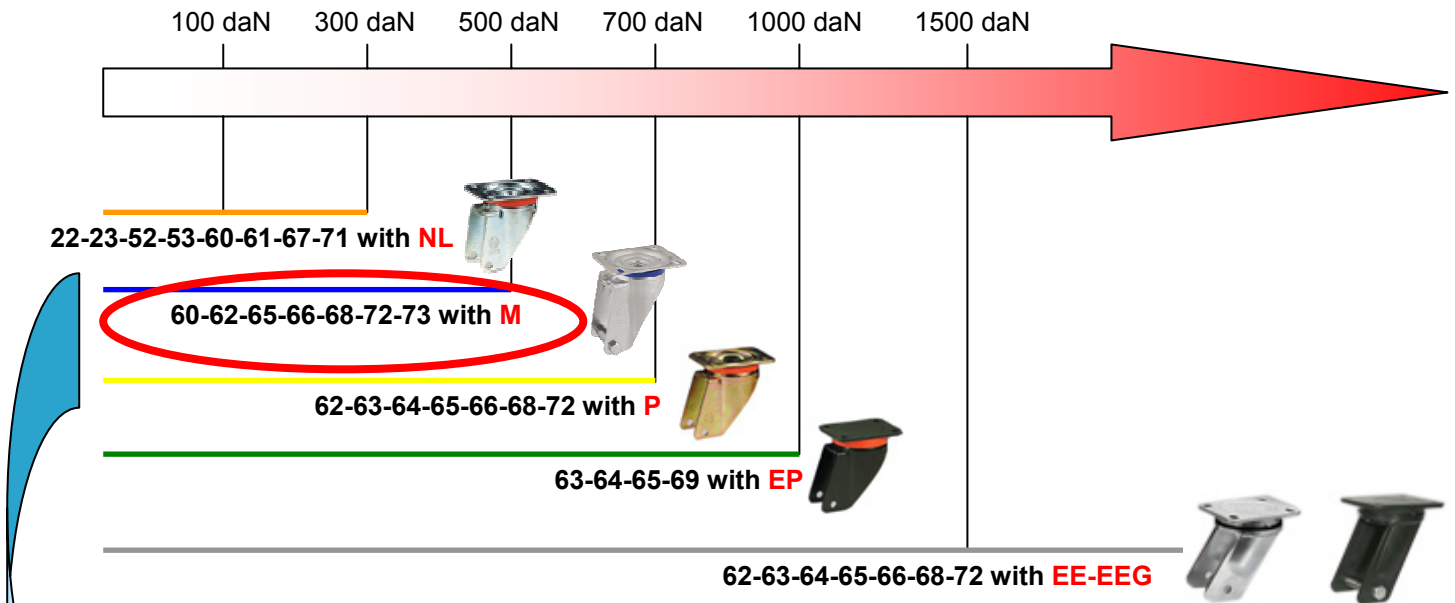

The M bracket is coupled to the wheels in the ranges:



Technical Features

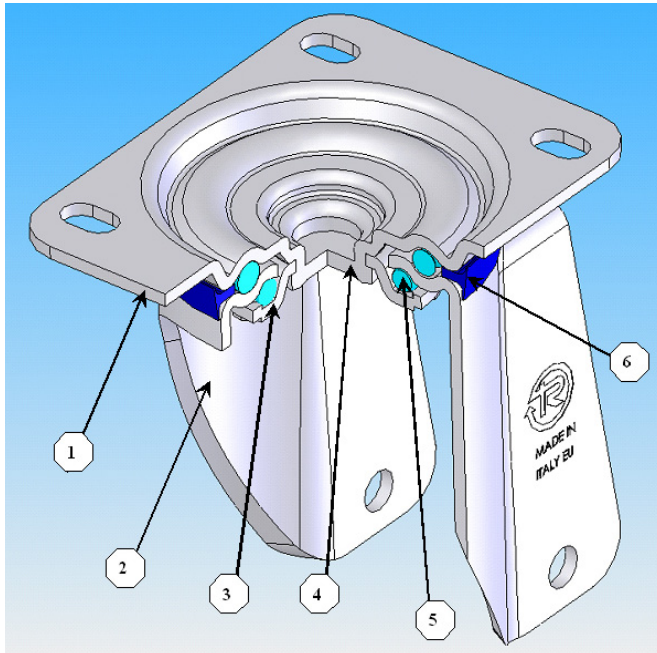

- 1) Plate: electrolytically zinc-plated steel plate
- 2) Fork: electrolytically galvanised steel plate
- 3) Ball Race Ring: electrolytically galvanised steel plate
- 4) King pin: incorporated in top plate and cold riveted
- 5) Swivel actions: double ring of greased balls
- 6) Dust seal: blue polyethylene

White zinc-plated. **The M bracket is compatible 2002/95/CE (RoHS).**

Diameters available: 150-160-200 mm
Load capacity: 500 daN

Braked bracket

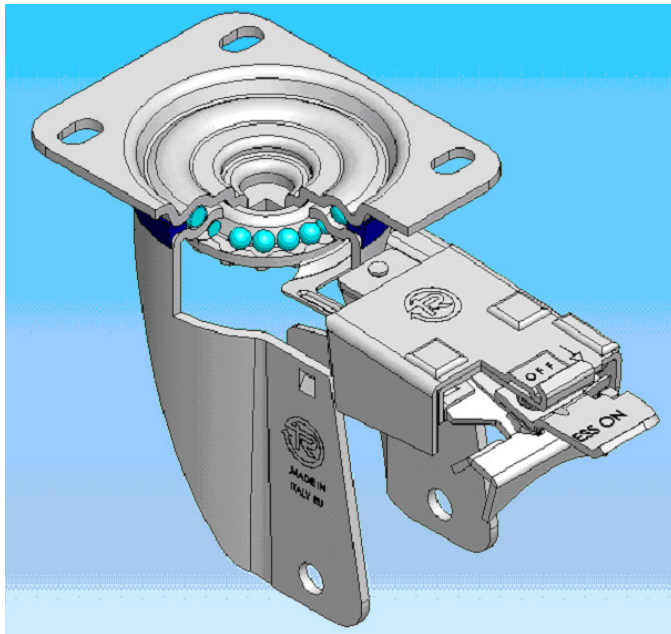

Adjustable front-locking brake

Double-action front brake that locks the wheel and the castor at the same time. Thanks to its optimised dimensions and fold-away pedal, the brake is easy to engage and extremely compact. Locking force can be adjusted using an M8 socket screw - 13 mm spanner. The brake for electrowelded castors is an adjustable brake, and consequently adjustment of the brake setting alters product braking efficiency. Before using the product, we suggest you check that the braking setting obtained by means of adjustment is suitable for specific operating requirements.

Dimensional specifications

150	60	194	140x110	105x80	11	56	12	500
160	60	199	140x110	105x80	11	56	12	500
200	60	240	140x110	105x80	11	56	12	500

For further information: tel. +39.059.410302 – fax +39.059.572859
e-mail: comm.estero@tellurerota.com